

B-VT

Peripheral Immersion Pumps



Construction

Vertical close-coupled peripheral (regenerative) pumps with submerged turbine impeller, seal-less, reversible.
Port dimension to EN 12157.
Submerged depth 170 mm.

Applications

For clean liquids without abrasives, without suspended solids, non-explosive, non-aggressive for the pump materials. For the reduced dimensions, these pumps are very well suited for use with temperature, controllers chillers, and air-conditioning machines and systems.

Operating conditions

Liquid temperature: - with water up to 90 °C.
- oil up to 150 °C.
Max. kinematic viscosity: 20 mm²/s at 50 °C (2,9 °E).
Ambient temperature: up to 40 °C.
Max. depression 0,9 bar.
Continuous duty.

Motor

2-pole induction motor, 50 Hz (n ≈ 2900 rpm).
B-VT: three-phase 230/400 V ± 10% (220-240 / 380-415 V).
Insulation class F.
Protection IP 54.
Constructed in accordance with: EN 60034-1.

Materials

Components	Materials
Pump casing	Bronze G-Cu Sn 10 EN 1982
Casing cover	Bronze G-Cu Sn 10 EN 1982
Impeller	Brass P- Cu Zn Pb 2 UNI 5705
Shaft	Chrome steel 1.4104 EN 10088 (AISI 430)
Bearing sleeve	Corrosion-resistant Cr-Mo steel
Bearing in the casing	Polymer
Screws	Cr-Ni steel 1.4301 EN 10088 (AISI 304)

Special features on request

- Terminal box arrangement 2-3-4 in accordance with EN 12157.
- Oil temperature up to 180 °C.
- Other voltages.
- Frequency 60 Hz.
- Protection IP 55.

Characteristic curves with water at 20 °C (ν = 1 mm²/s) n ≈ 2900 rpm

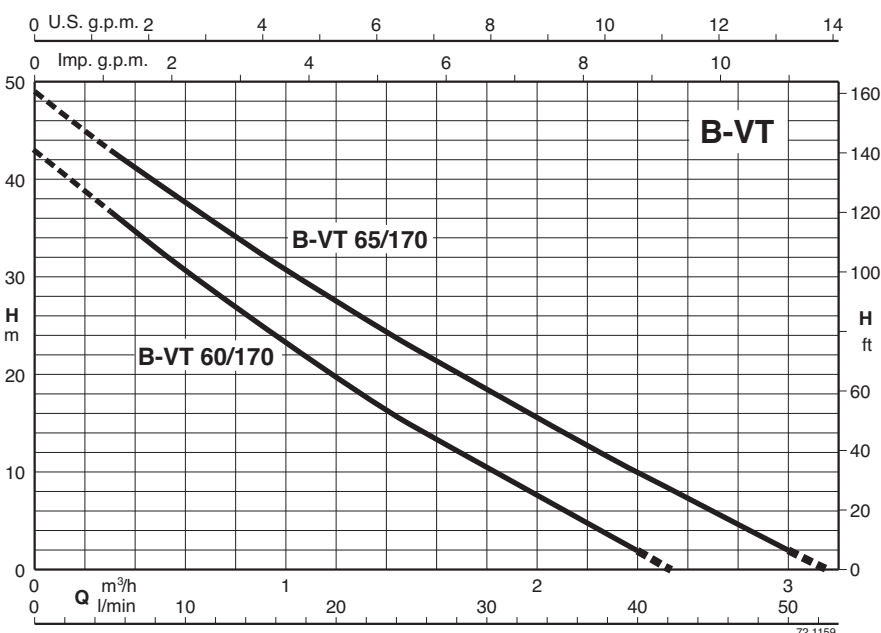

B-VT Peripheral Immersion Pumps



Performance $n \approx 2900$ rpm

3~	230V 400V		P ₂		Q	H											
	A	A	kW	HP		m ³ /h	0	0,3	0,48	0,6	0,75	0,96	1,2	1,5	1,89	2,4	3
					l/min	0	5	8	10	12,5	16	20	25	31,5	40	50	
B-VT 60/170	1,9	1,1	0,33	0,45	H	43	37	33	30,5	27,5	23,5	19,5	15	8,5	2		
B-VT 65/170	2,8	1,6	0,45	0,6	m	48,5	42,5	39	37	34,5	31	27	23	17,5	10	2	

P₂ Rated motor power output.

H Pump outlet head

Dimensions and weights

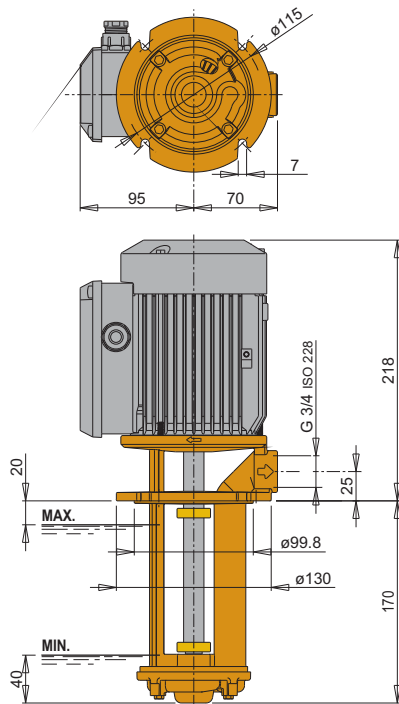

B-VT 60/170: kg 8,2
B-VT 65/170: kg 8,4

Terminal box arrangement (view from motor side)

EN 12157

1
Standard

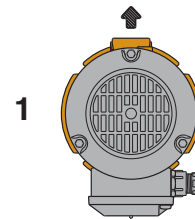

2, 3, 4
On request

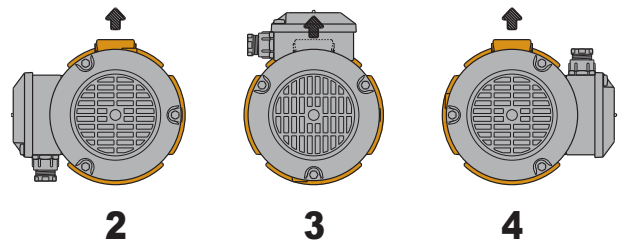

Features

Range

The high number of pumps in the range can meet the widest range of services required by the user.

Construction with no mechanical seal

The absence of a mechanical seal minimizes the need for maintenance of the pumps.

Float switch

The pumps can be fitted with a float switch, eliminating the need for level control systems.

